

FB-7050-S TALL SHALLOW MOUNT BOLLARD SYSTEM

ITEM NO.	DESCRIPTION	MEASURE	REBAR QTY/BOLLARD
1	M50 P1 Shallow Mount Bollard		
2	#7 Horizontal rebar for 15ft Foundation	CONTINUOUS	14
3	#7 Vertical rebar	7'-6"	4
4	#7 Bent Rebar	4'-10"	7

GENERAL NOTES

1. For additional information contact Sloan at 1-800-275-5998. All
2. concrete shall be per specification; minimum 5000PSI with a maximum water to cement ratio of 0.45.
3. All rebar is #7 and should have 3" minimum clear cover.
4. Rebar and concrete not provided by Sloan.
5. Continue bollard and rebar pattern for longer array installation.
6. Ⓚ Horizontal bars must be installed continuously for a minimum of three consecutive bollards. Overlapping of horizontal bars not required between arrays.

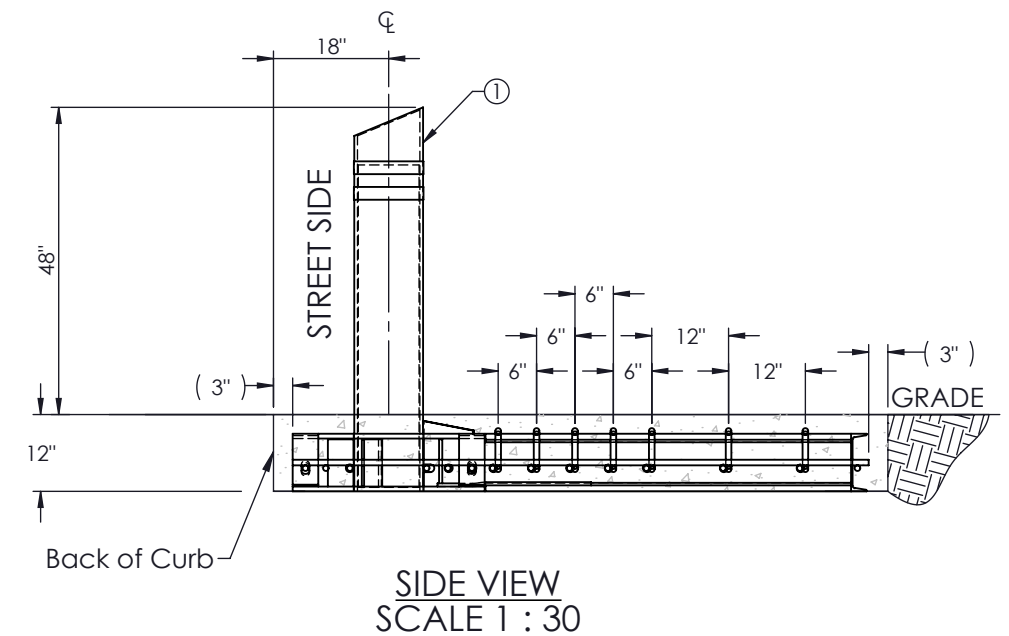
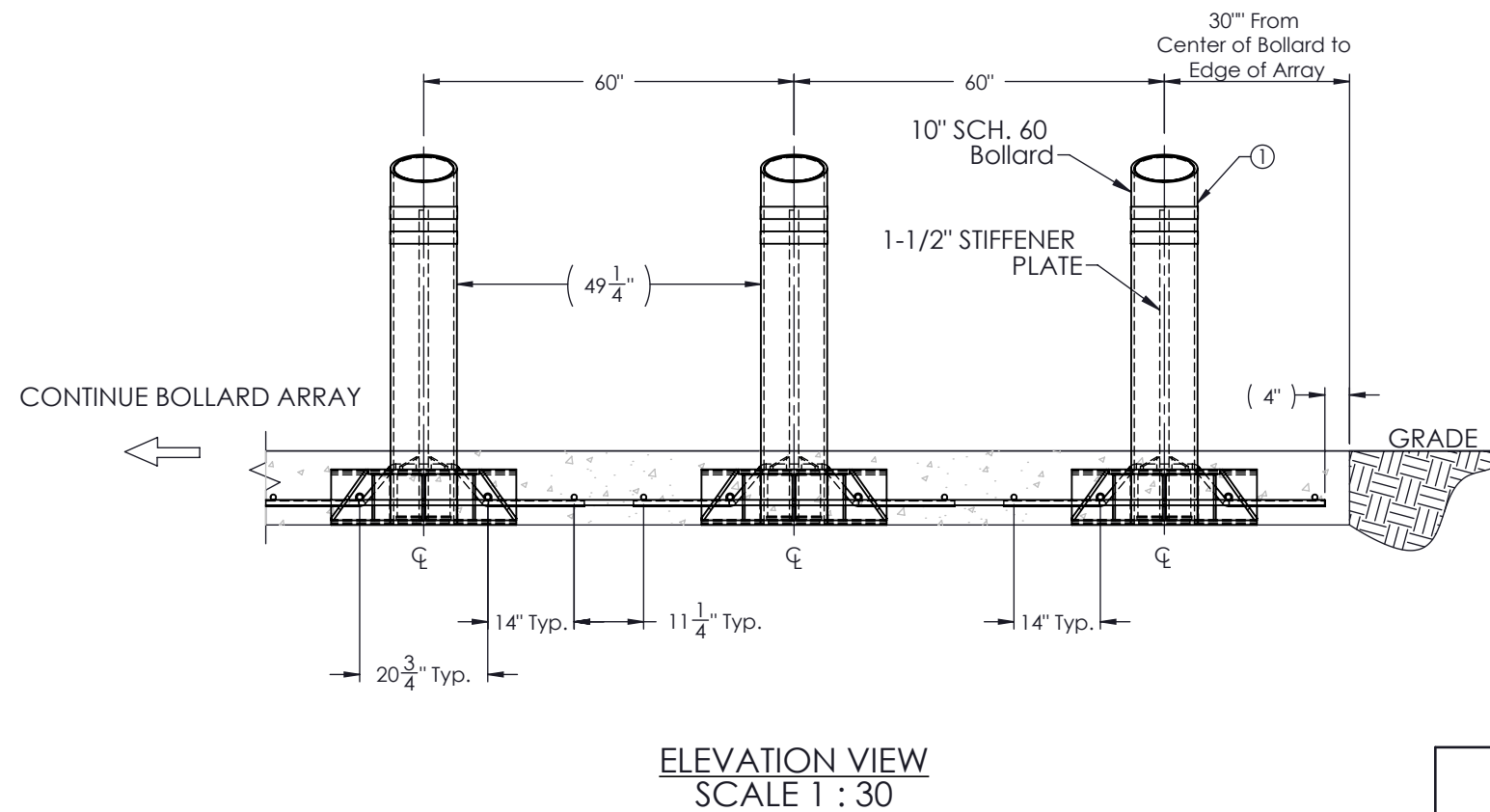
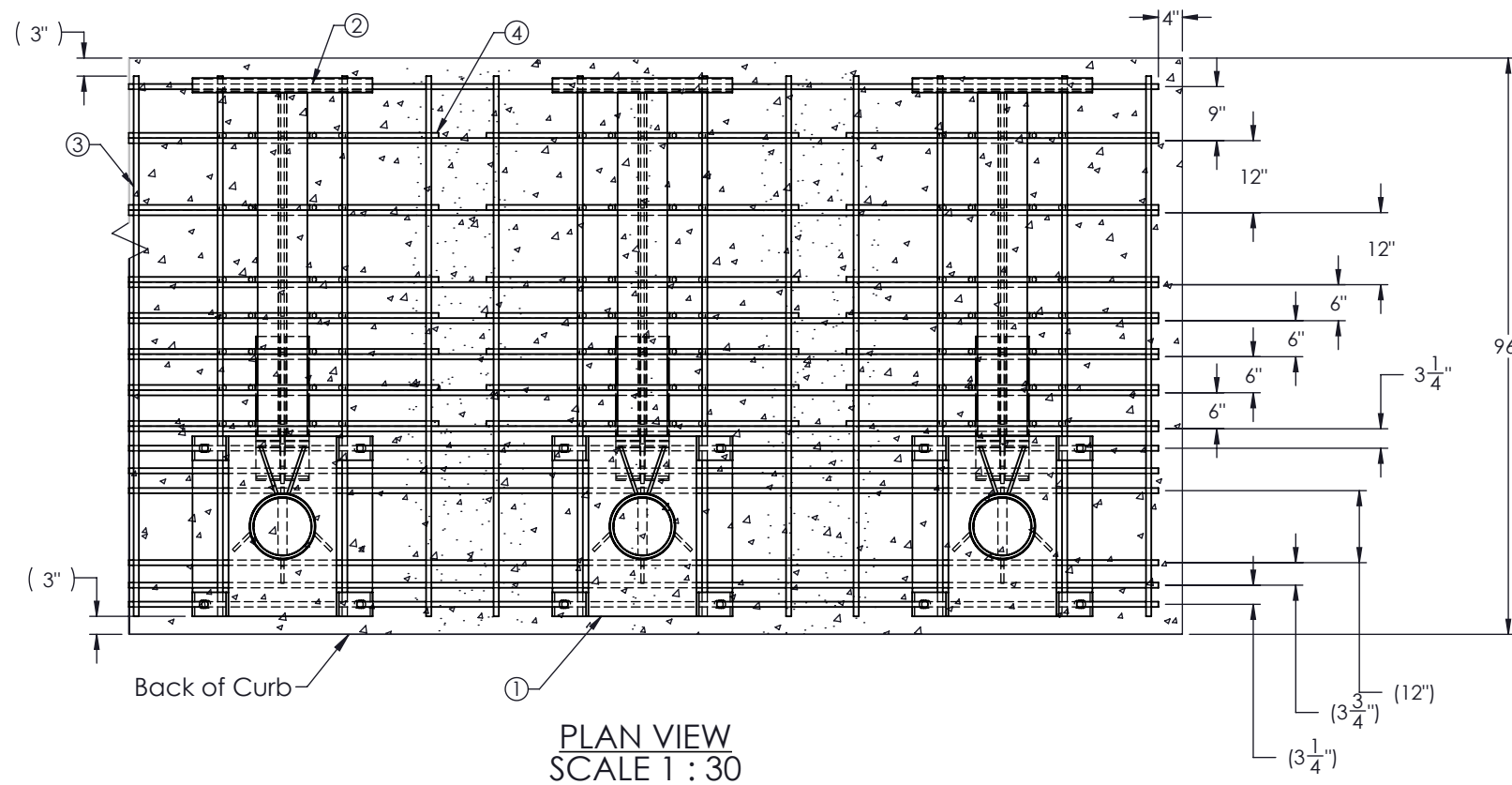

THE DRAWINGS AND INFORMATION CONTAINED
HEREIN ARE PROPRIETARY AND CONFIDENTIAL. ALL
RIGHTS RESERVED

PRODUCT:
FB-7050-S M50-P1
Tall Shallow Mount Bollard

SHEET DESCRIPTION:
3-Bollard Layout



PROJECT:

SCALE: Varies SHEET: 1 OF 1 DWG #: 7050-S-LVCC-SB