

Drain Line Locations Plan View
Scale 1:30

Vehicle Attack Direction

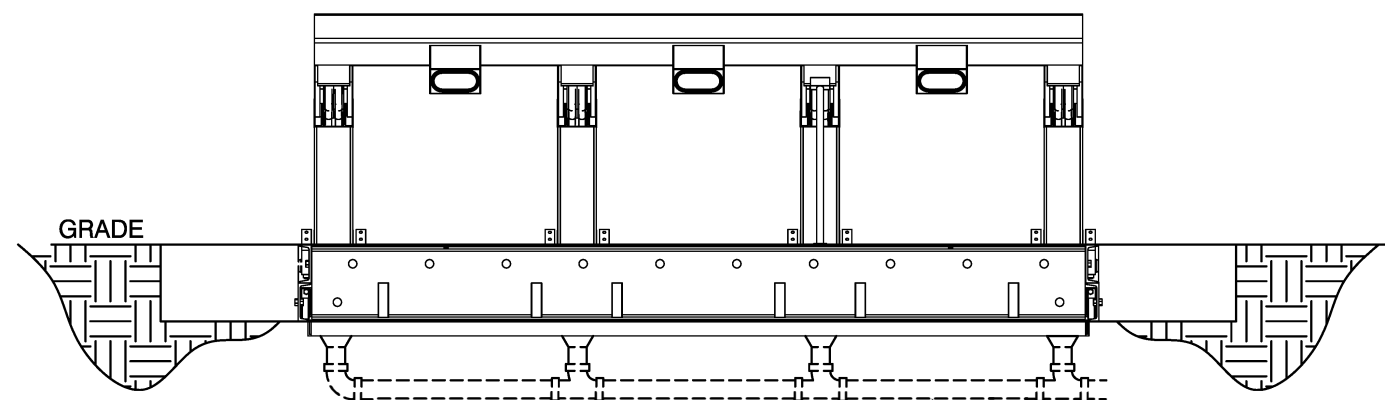

Drain Line Locations Elevation
Scale 1:30

Drainage Notes:

1. The EW-7050 Electric Wedge Barrier is designed to operate in wet conditions, it is a good practice to keep barrier and subgrade areas of the barrier free from submersion. This can be accomplished in the following ways:
 - 1.1. The installer shall provide the barrier with a drain line plumbed to a storm drain, drainage field, or a sump pump (if needed).
 - 1.2. There are eight 3" diameter holes in the bottom drain pan of the barrier. These should be plumbed based on the elevation of the roadway.
 - 1.1.1. Plumb either the front four drain holes, or the rear four drain holes. Plumb the holes on the downhill side depending on the slope of the roadway. Cap unused holes.
 - 1.2. When the barrier is installed on level grade or a down hill slope (sloped to the asset side), raise the front of the barrier 1" above grade and slope the foundation to the roadway away from the barrier. Raise the back of the barrier 1/2" above grade and slope the foundation away from the barrier. Plumb the rear four holes.
 - 1.3. When the barrier is installed on an uphill slope (sloped to the asset side), raise the entire barrier 1" above grade and slope the foundation to the roadway away from the barrier. Plumb the front four drains.

Horizontal Drainage Port Dimensions

Barrier Blocking Width	A	B	C
8ft	2'-9 1/2"	5'-3 1/2"	7'-9 1/4"
9ft	3'-1 1/2"	5'-11 1/2"	8'-9 1/4"
10ft	3'-5 1/2"	6'-7 1/2"	9'-9 1/4"
12ft	4'-1 1/2"	7'-11 1/2"	11'-9 1/4"
13ft	4'-5 1/2"	8'-7 1/2"	12'-9 1/4"
14ft 6in	4'-11 1/2"	9'-7 1/2"	14'-3 1/4"

PRODUCT: EW-7050	DESCRIPTION: Wedge Barrier Drain Holes (Domestic)		
	PROJECT: STANDARD		
	SCALE: NTS	SHEET: 1 OF 1	DWG # G2-DH-D

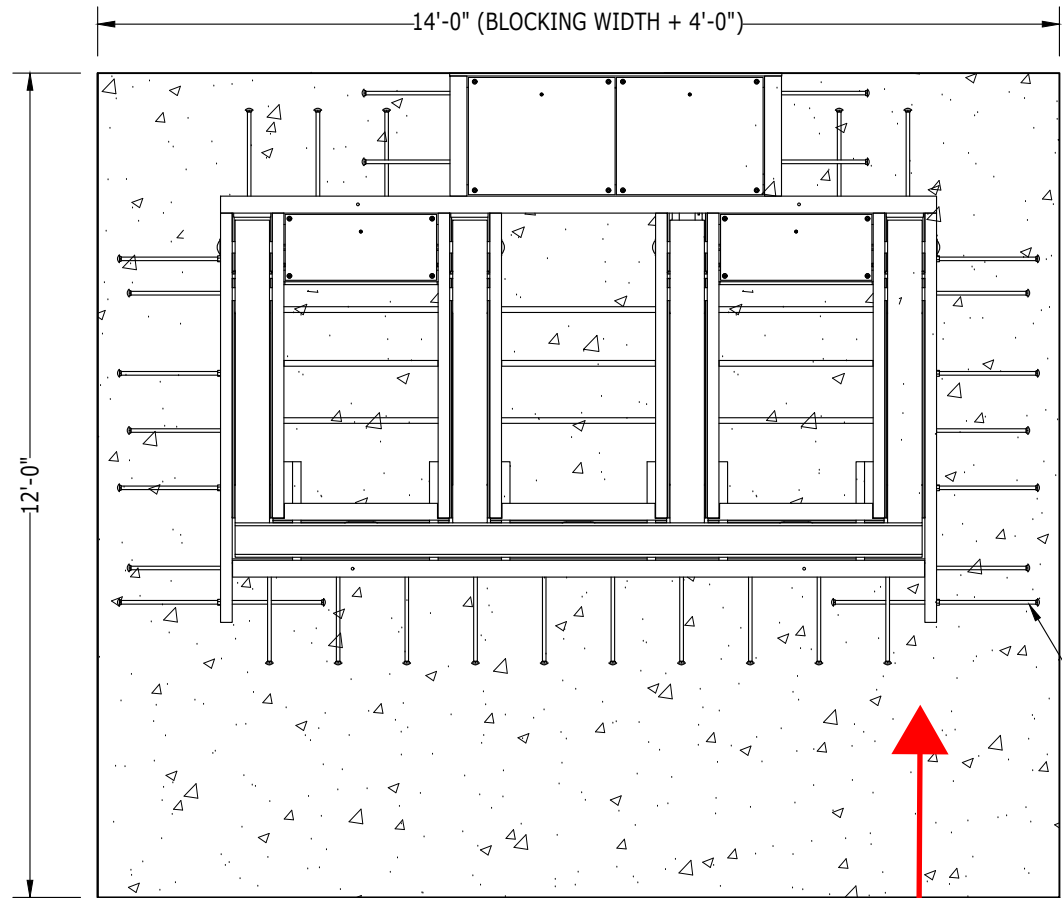

PLAN VIEW (DISENGAGED)

Vehicle Attack Direction

5/8" DIA. x 18" long Carriage Bolts installed on site. Provided by Sloan Security Group. (No Rebar Required)

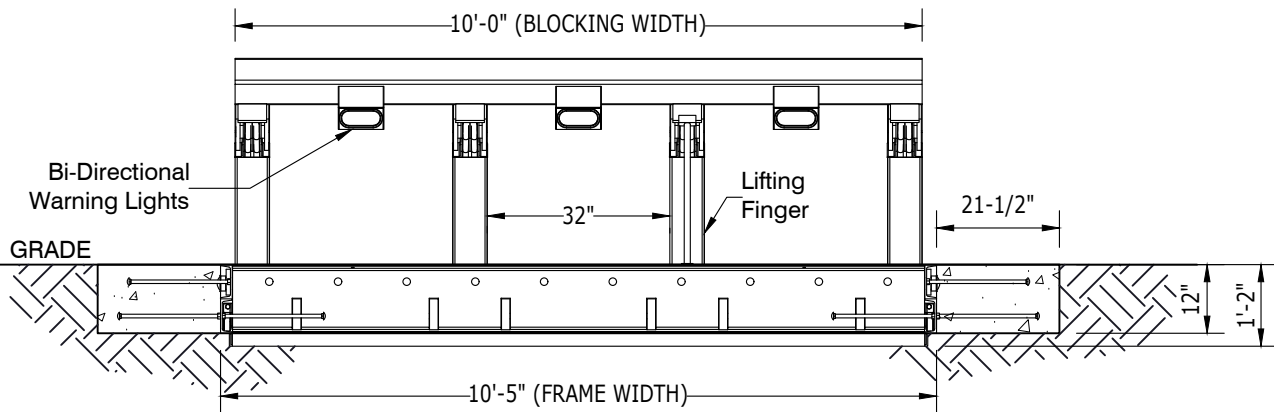

ELEVATION VIEW (ENGAGED)

- ### GENERAL NOTES
1. For additional information contact Sloan Security Group at 1-888-382-8379.
 2. All concrete shall be per specification; minimum 3500PSI.
 3. The EW-7050 Electric Wedge Barrier ranges in Blocking Width from 8ft to 14ft-6in.
 4. As standard, the Sub-grade frame is Hot Dip Galvanized to ASTM A 123. Blocking frame to be coated per customer specification. This can be Galvanized, Powder Coated, or Wet Painted to include customer specified designs.
 5. Channel Iron is welded to the underside of all finger troughs and blocking member trough and sits 2" below sub-grade (not incased in concrete) with 3" DIA. holes for drainage purposes.

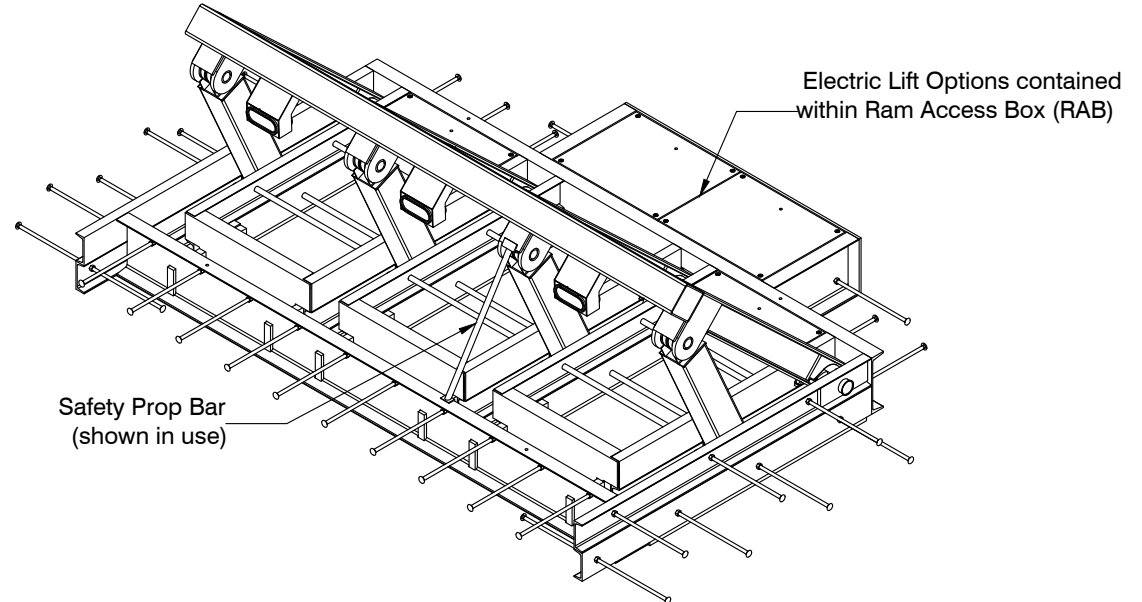

ISOMETRIC VIEW (ENGAGED)

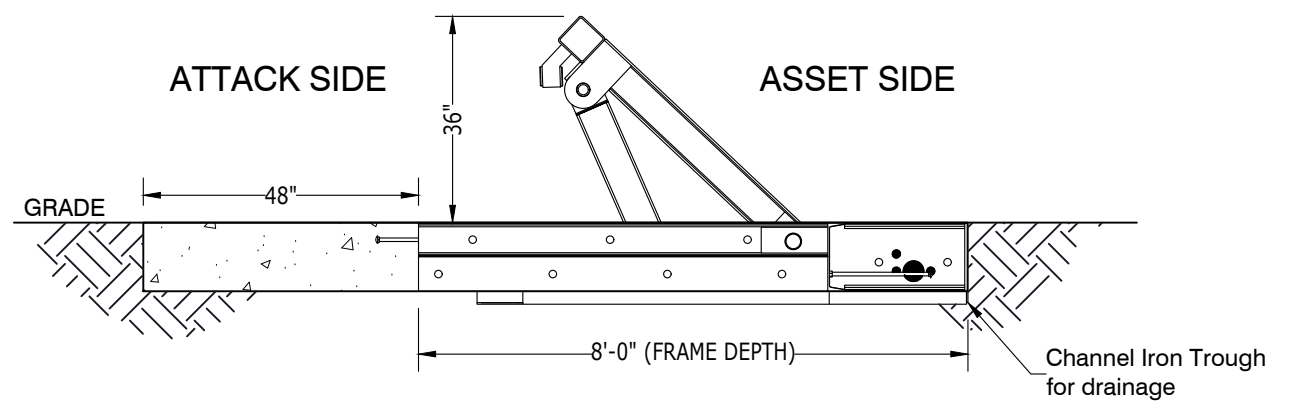

SIDE ELEVATION VIEW (ENGAGED)

PRODUCT: EW-7050	DESCRIPTION: (M50 P1) 10ft Wedge Barrier
	PROJECT: STANDARD
	SCALE: NTS
DWG # G-2010-SL	